

1915/1927

COTTON MOTOR CO.

AMAC

THE CARBURETTER
RECORDS & SUCCESSES

CATALOGUE AND HINTS & TIPS

AMAC LIMITED
HOLFORD WORKS, PERRY BARR
BIRMINGHAM

1927 EDITION

CATALOGUE
AND
HINTS & TIPS

AMAC
Carburettors & Controls

AMAC LIMITED
HOLFORD WORKS
PERRY BARR
BIRMINGHAM

Telegrams: "TERMINALS, B'HAM"

Telephones: | EAST 478 | B'HAM
| EAST 477 |

INDEX

HINTS AND TIPS

- SECTION 1 General
" 2 Fixing to machine
" (a) Petrol Pipes; (b) Controls; (c) Air Leaks;
" (d) Sticking Valves
" 3 Setting Carburetter
" 4 Jet Size for Speed Work
" 5 Easy Starting
" 6 Economy
" 7 Pilot Jet Carburetter
" 8 1925 T.T. Carburetter
" 9 Two-Stroke Notes
" (a) Lubrication; (b) Magneto Timing
" 10 Trouble
" (a) Absolute; (b) Conditional
" 11 Fuels
" 12 Dodges to get Home
" 13 Settings 1915-1919 Carburetters
" (a) Settings for 1915-1919 Two-Stroke Carburetters
" (b) Carburetter Settings, Pilot Jet and T.T. Types
" 14 Engine Revolutions at different speeds
" 15 Cubic Capacity of Standard Size Engines

CATALOGUE

- SECTION 16 Ghost View of Pilot Jet Carburetter
" 17 Price List and Illustrations of Spare Parts
" 18 1926 Successes of "AMAC" Carburetters
" 19 Illustrations of "AMAC" Carburetter Controls and
" Twist Grips
" 20 Price List of "AMAC" Carburetters, Controls and
" Twist Grips

AMAC CARBURETTERS

Patented

SECTION I: GENERAL.

To the average motor cyclist the principally desired function of a motor cycle is: "Taking him there; bringing him back."

The object of these brief notes is to spread carburetter knowledge, enabling the average rider, so far as his carburetter is concerned, to "get there and back," no matter what the road or weather, in confidence and comfort—not once, but always.

The various parts of a motor cycle are intimately related one to another, and their functioning, good or bad, affects the running of other parts. Of no part is this more true than the carburetter. It has within its power to affect ignition. It affects the wear on the bearings, for the heavy kicking motion produced by carburetters which pass gas which is incorrectly atomised spells short life to bearings. Under atomisation leads to excessive piston wear, as the heavy unvaporised residues, which will not explode, wash the cylinder and piston, causing undue wear.

Transmission and tyres are also affected, heavy impulses wearing them out sooner than soft ones. This also shakes keys loose, lessens the life of the gears and other parts generally. Burnt-out exhaust

valves are (apart from errors of valve and magneto timing, and unsuitable metals, etc.) due to carburation, chiefly caused by too weak a mixture. Safety on "greasy" roads is assisted by correct carburation. A carburetter that will only pull jerkily at slow running is far more likely to cause you to skid than one which delivers its impulses smoothly. It's all the difference between being pushed along and kicked along; the same power is exercised in both cases.

SECTION 2: FIXING TO MACHINE.

The points to watch are: That the carburetter is fixed vertically; that the float chamber assumes a slightly higher position when climbing a hill, thus raising the level of the float chamber (raising the petrol level). In practice this is attained by placing the float chamber slightly in advance of the mixing chamber in the direction of the machine's travel. If flange fixings are used, give each nut a turn alternately. Do not screw one up tight and then afterwards the other, which will not give a good joint.

Avoid placing the carburetter in a direct cold draught. If impossible, then shield it, as it works best in as even an air stream as it is possible to obtain.

SECTION 2A: PETROL PIPES.

See that the pipe is formed so that it goes into position easily. A pipe strained into position is bound to break soon. The pipe should sometimes be detached and re-annealed by heating to bright red and plunged into cold water. Pipes curved and looped horizontally are less liable to cause air lock than those where the loop is vertical.

SECTION 2B: CONTROLS.

Lubricate levers with engine oil. The wires are treated with a special preparation before being fitted up, and should only be oiled at the control end.

Avoid sharp bends in cables, as they cause wires to work stiffly.

"AMAC" standard controls open inwards, but controls opening outwards may be had to special order.

Adjust the cables when the carburetter is fitted and all wires in their final position, as bends in the cable alter the adjustment between the cables and the wires. Put the levers in the closed position, then screw adjusters at the top of the carburetter in or out until all slackness in the cable is just taken up. When doing so, hold the cable to prevent it from twisting with the adjuster.

SECTION 2C: AIR-LEAKS.

It is most important to do everything possible to avoid air-leaks, as they affect Slow Running, Easy Starting, Pick Up, or Acceleration; also, indirectly, Consumption.

Absolute freedom from air-leak on the engine side of the throttle is, in the case of poppet valve engines, practically impossible owing to leakage past the valve guides, but if engine designers would pay more attention to this most important point, they would considerably simplify the carburation problem. Nevertheless, air-leaks can be largely eliminated by observing the following points:

It is important that the induction pipe should be long enough to allow the shoulder in the carburetter outlet to come into contact with the end of the pipe.

If the carburetter is a slack fit on the induction pipe a little gold size or shellac varnish smeared over the pipe before fitting the carburetter will ensure an airtight joint being made. Consider, for all practical purposes, the mixing chamber as a part of the induction pipe, removing it only in the most extreme cases.

One of the greatest difficulties with air-leaks is on twin engines of the V type, owing to the difficulty the makers experience in getting the induction pipe faces to align, and also to the fact that the cylinders under variation of temperature tend to draw the port faces apart. Under these conditions it will be appreciated that to even the most careful manufacturer the problem is a difficult one. The private owner, if careful, may do a lot to minimise this trouble. In cases where large nuts are used to bring the faces together, compressed annular cork washers make a splendid joint. A point against them is that the use of benzol affects them badly. Copper and asbestos washers, if the right size can be obtained, are good. Asbestos, or even ordinary string, soaked in gold size and placed between the faces, forms a fairly satisfactory substitute. The width of the faces are usually too narrow to allow of a ring being made from any of the well-known packings. The manufacturers are, quite rightly, loth to rely upon artificial joints because owners occasionally forget to replace them or re-make them properly.

For flange joints use washers made of any good jointing, preferably of the graphite type. Thick brown paper soaked in gold size makes fair joints, though they are not to be strongly recommended on air-cooled engines, and the flange should be bolted up whilst the washer is wet.

Insulating tape is a good temporary measure for overcoming air-leaks, but should be replaced from time to time, as when dry it is of no value, and will not prevent air-leak.

Accurate machining and gold size make by far the best job.

SECTION 2D: STICKING VALVES.

Sticking valves are practically unknown with the "AMAC," but may occur if the carburetter is fixed in such a position that an undue amount of mud and dust is thrown on the air-intake, and this point ought to be watched. If the valves do not work freely, it is generally due to their being bruised when dismantled, or to the Bowden wire being kinked, being fitted with a sharp bend or having rusted up. In exceptional circumstances in foggy weather, freezing might take place, but this only applies to machines on which the carburetter is very much exposed. The only cure for this is to fit a hot air pipe to the air-intake or shielding the carburetter. The valves should never be oiled, as this causes dust to collect on them. They may, however, be rubbed with graphite if desired.

SECTION 3: SETTING CARBURETTER.

Usually it will be found that the setting on the carburetter fitted to the machine will be quite all right, but perhaps the owner of the machine lives in a district where the hills are bad, and really requires slightly more power than obtained with the standard setting. The only alteration necessary will be a slightly larger jet.

In cases where the rider lives in a flat district, and wishes to economise as much as possible, he may fit with advantage a slightly smaller jet.

Presuming that the carburetter has not been set for any special engine, the method of tuning up should be as follows:

The correct jet size for maximum power should first be obtained. This necessitates an actual road test, and should be done, if possible, with the aid of a stop watch, and along a measured distance of straight level road. The jet which gives the maximum speed with the throttle fully open and the air lever about one-quarter closed is correct.

It may be as well to state here the reason for the air lever being one-quarter closed with the throttle fully open. Under normal conditions the engine requires a certain proportion of air to petrol. This proportion varies according to atmospheric pressure and air temperature, less petrol being required on a warm day, and more on a cold day. By selecting the jet which necessitates the air lever being one-quarter closed for full throttle, the rider can, by opening or closing the air valve more or less, obtain the necessary adjustment for varying atmospheric conditions. It is obvious that, if the jet under normal conditions

requires full air, on a warmer day it would not be possible to correct the mixture.

Once the correct jet size has been obtained, it should not be altered to rectify the mixture strength at any other throttle position.

The carburetter should now be tuned for lower throttle openings and acceleration. It will usually be found that, provided the mixture is correct for lower throttle openings, the acceleration will be satisfactory.

Mixture strength from closed to about half-throttle is controlled by means of the throttle valve. This throttle valve is bevelled on the air-intake side, and acts as a valve on the air-intake. The standard valve is No. 3, the number being stamped on the base of the spring container near the Bowden nipple.

If it is found that the mixture at small throttle openings is too rich with the No. 3 valve, it will be necessary to fit a valve with more cut-away, i.e. No. 4 or No. 5. If, on the other hand, the mixture is too weak, it will be necessary to fit a No. 2 valve, which has less cut-away. It will be easy, by trial, to select the correct throttle valve.

As the action of the throttle valve supplements that of the air valve to a certain extent, it will be found that for all ordinary variations in speed it is not necessary to alter the air lever. Of course, on a steep hill when the engine speed drops and the engine labours, the air lever should be closed down, the correct position being determined by the feel of the engine. Although it will be found that the machine will run with the throttle very nearly closed and the air lever full open owing to the supplementary

action of the two valves this must not be taken as an indication of too large a jet, or that the carburetter does not give enough air, but this is a natural consequence of its semi-automatic action. Neglecting the finer points, there are practically only three positions for the air lever.—Closed for starting; a quarter to half-way open for traffic; three-quarters to full for country roads.

Approximate sizes of jets to suit different sizes of engines are given as an indication of what ought to be fitted, and are shown on pages 22, 23, 24. Engines of the same capacity do not always call for the same size jet. We have found, as a rule, the rider has a tendency to fit too large a jet.

SECTION 4: JET SIZE FOR SPEED WORK.

If the carburetter is to be tuned for speed work or hill climbs, a jet should be fitted which will allow the air lever to be fully open. It will, however, be necessary, when finding the correct jet size, for the trials to be done under similar conditions to those which will hold at the competition itself.

SECTION 5: EASY STARTING.

With the carburetter correctly set, easy starting is a matter of freedom of pistons and a hot spark at the plug. It is sometimes necessary to inject paraffin into the cylinder to free the piston from the thick oil, so that the engine can be revolved sufficiently fast to obtain a good spark at the plug.

There is a possibility of failure to start if you flood too heavily. Three short depressions of the needle is the utmost required, and when warm, flooding is unnecessary. Do not open the throttle too far. On type E do not open more than a quarter, keeping air shut.

SECTION 6: ECONOMY.

Having set for maximum power and obtained good results, you will find the consumption bears favourable comparison with other carburetters. The point then to watch is that you are not robbed of the benefits the carburetter gives you by such power wasters as slipping clutches or belts—too tight chains or belts—excessive valve tappet clearances—poor sparks at plugs—brakes that are never really off—late ignition—too low a top gear—too high a top gear, leading to excessive call for second speed—weak valve springs—poor compression—choked silencers—sidecars out of line with motor cycle.

Heavy consumption caused through faulty carburation is generally due to too rich mixture, either through too large jet being fitted or through flooding. It might also be caused through the air gauzes gradually getting stopped up with dust. Undue vibration is another reason.

SECTION 7: 1926 STANDARD PILOT JET CARBURETTER.

While the previous sections on tuning apply also to our 1926 carburetter, the following instructions are peculiar to the pilot jet model only.

Adjustment.—The Pilot Mixture is adjustable by means of the knurled cap on the Mixing Chamber side, which regulates the amount of petrol issuing from the Pilot Jet.

To weaken the mixture turn the knurled cap clockwise, and *vice versa* to richen. This adjustment must be made gradually, the knurled cap being turned one notch at a time only.

The approximate setting will be found between one-half and one complete turn open, depending on the capacity of the engine. Final adjustment should be made with the engine running. Open throttle one-quarter and air one-half. Gradually close throttle until the engine speed is reduced sufficiently. Turn the knurled cap until even firing is obtained, and if necessary further shut the throttle lever; then re-adjust the Pilot Jet until the desired idling is effected.

The adjustment for slow running is dependent on the position of the throttle and the opening of the Pilot Jet, one cannot be altered without affecting the other. Finally, use this adjustment for obtaining slow running only, and beware of air leaks at the joint between the carburetter and the induction pipe.

It is most important that no undue force is exerted in shutting off the pilot needle valve—otherwise the needle and seating may become seriously damaged.

Starting.—To ensure ease of starting the throttle should only be opened slightly, so as to put a high depression on the pilot outlet. When cold the air lever should be shut, but with a warm engine this is not necessary.

SECTION 8: 1935 T. T. CARBURETTER.

This carburetter is a stream-lined highly-efficient instrument. The petrol is first formed into an emulsion of air and petrol before passing into the main choke. The amount of air passing through the primary choke controls the main jet depression and

consequently mixture strength. This regulation is obtained by means of a small piston valve which, set for given atmospheric conditions, makes the carburetter fully automatic.

An adjustable pilot jet is incorporated in this carburetter to give slow running and easy starting. The fuel supply is regulated by a taper needle, which should be adjusted to approximately three-quarters of one complete turn in an anti-clockwise direction. It is most important that no undue force is exerted in shutting off the pilot needle valve—otherwise the needle and seating may become seriously damaged.

All-out mixture strength with the air lever fully open should next be determined, this being governed in the full throttle position by main jet size only. The smallest jet which gives the maximum speed being the correct size. After this has been decided intermediate running and acceleration should be dealt with. If it is found that the mixture is too rich a throttle valve with more cut-away should be tried. On the other hand, if the mixture is too weak a valve with less cut-away should be used. The higher the number stamped on the valve, the bigger the cut-away.

It is important that the correct jet size for all-out should be obtained before tuning for general running. It is well to bear in mind that the cut-away of the throttle valve does not have any effect on the all-out position.

Owing to the stream-lined shape of the carburetter a larger outlet than usual is necessitated, but realising that in some cases the carburetter has to be fitted on a standard induction stub, a special liner is supplied, but we recommend in every case where possible that the carburetter should be used without a liner.

SECTION 9: TWO-STROKE NOTES.

The carburation of these from a flexibility point of view is one of the greatest problems confronting the engine designer to-day. It lies primarily in the fact that though the conventional type of two-stroke motor cycle engine crankcase is really part of the carburetter, it is designed as a crankcase only. Its functions as a pump and vaporiser are disregarded. Despite these handicaps, our latest model will be found to be a revelation in slow running and pulling against load.

The same points are to be observed in setting as for a four-stroke. When using "Petroil" lubrication, a size or two larger jet is necessary, as the quantity of oil also passing through the jet naturally reduces the quantity of petrol. Though we would again urge the rider to guard against using too big a jet.

With two-strokes as at present made, a certain amount of four-stroking is often observable going down hill, and sometimes when going fast down long gentle slopes. It should not be present at any speed above eight miles per hour on the flat, and if it is, something wrong with the carburetter is indicated, usually too rich a mixture.

Too weak a mixture is indicated by firing back through the carburetter, though on starting away on a cold morning, till the engine gets warm, a slight tendency to spit back may be noticed. If the machine, previously running well, starts suddenly to blow and spit through the carburetter and, upon examination, any evidence of weak mixture being caused by the carburetter, such as dirt in jet or sprayer holes, is absent, then the most probable cause of the trouble is

a blown joint between either the induction port faces, the transfer port inspection door faces, or cylinder and crankcase register faces. In the dark these can be very quickly located by the flame coming through them, but by day the force of the explosions can be felt by passing one's hand round the engine whilst running on the stand. Another cause is that on crankcases with taps to release excess oil, these get accidentally turned on, and sometimes plugs fitted for the same purpose fall out, when symptoms develop.

SECTION 9A: LUBRICATION.

With engines lubricated by drip feed, great care should be taken to guard against excess of oil, as this, more than bad carburation, is the chief cause of four-stroking. Do not use too thick an oil. The "Summer" grade supplied by makers will give a good deal of trouble if used in cold weather with drip feed. If "Winter" grade is not available, mix about 25% of good water-cooled oil with the "Summer" grade. It will save you a great deal of trouble, especially when getting away first thing in the morning.

With the "Petroil" system of lubrication, the oil is mixed with the petrol and fed through the carburetter, separating out later in the crankcase. The proportion should be about sixteen to one of petrol and oil respectively, but the maker of the machine should be approached.

A tendency will be noticed when the machine is stationary for the oil to sink to the bottom of the tank and float chamber. This can be overcome by shaking (rocking gently from side to side is sufficient)

the machine, and agitating the liquid in the float chamber with the needle. It is also a good thing when finishing a run to turn the petrol off a little before stopping, and so ensure an empty float-chamber.

SECTION 9B: TWO-STROKE NOTES. MAGNETO TIMING.

Magneto timing is a very important factor in successful two-stroke running. They will stand a very much earlier firing point than fours. This is not so widely known as it should be, and four-stroke methods of timing, by even those who should know better are frequently employed. Then the carburetter gets blamed because the engine over-heats, and the petrol consumption is high.

When two-strokes are "revving" the point to which the ignition can be safely advanced seems out of all proportion compared to four-stroke practice, and is frequently disbelieved by those without experience.

There are two methods of treating the matter, and the reader can take his choice. One is to treat the magneto as a fixed ignition, setting it so that there shall be no knock even on the steepest hill. This is translated into practice by causing the platina on the contact breaker to commence to separate when the piston is about 4 m/m from the top on the "compression" stroke.

The other way is to recognise that ignition is capable of being advanced and retarded, and setting your timing for maximum speed to use the advance and retard lever with discretion. A fair setting for maximum speed would be:—Platina separates on fully advanced contact breaker when piston is from

ten to twelve millimetres from the top on the "compression" stroke. Providing always that the firing angle allowed by the movement of the contact breaker will allow of a retard back to 3 m/m, should a steep hill with a head wind blowing down it call for it.

With this setting you will find you can start away on half advance, do most traffic work on five-eighths to three-quarters, and when the open country comes and the road opens long and straight before you, you can fully advance, and wipe out the oft-repeated slur "that two-strokes cannot move."

Though this booklet purports to deal with carburettors, we have written thus on lubrication and magneto timing because there is a tendency to presume these two items always perfect, whereas they are far more often to blame for bad running than the carburetter.

SECTION 10: TROUBLE.

Carburetter trouble divides itself into two forms—absolute, in which your engine completely stops, indicating that the carburetter has ceased to make gas; or conditional, in which it makes gas badly, the running depending on how badly.

SECTION 10A: LOCATION OF CARBURETTER TROUBLE —ABSOLUTE.

Your motor stops and you wish to verify quickly the carburetter. Work throttle lever to make sure cable is not broken, so allowing throttle to remain closed; presume you find this in proper action—see that you have petrol in the tank and that the tap is turned on—take down jet and sprayer, and if choked you have found your trouble. Clear out with fine

wire or, by blowing through, replace, and proceed on your way. If you find jet clean remove float chamber top; if full of petrol, then suspect passage between float chamber and mixing chamber, so take out float (LOOK for water at base of float chamber), and clean passage with piece of copper wire. If clear, take down petrol pipe, and verify clear passage by blowing through.

Water.—One of the most frequent causes of sudden stoppage and missing is water in petrol. In the damp moist English winter, especially where machines are stored in cold sheds, the moisture in the atmosphere condenses in the tank, passing through the filters in the form of very fine globules, and unfortunately accumulates in the float chamber. Now the AMAC, owing to its concave base float chamber and petrol passage being placed high, will stand this sort of thing to an extent that would place most carburetters out of action, but even the "AMAC" occasionally protests and gently reminds you that carburetters will not "do their work on water." It only takes two minutes to clear it out, so it is well worth doing regularly in comfort, lest it should have to be done compulsorily on a wet, cold night.

If upon your examination petrol is passing through the jet, your throttle is opening, and there is no water, cease at once to suspect the carburetter, and examine other parts of the Power Unit.

SECTION 108: LOCATION OF CARBURETTER TROUBLE.

Conditional.—Motor runs hot through carburetter fault, therefore, gives too weak a mixture; try change of jet.

Very poor pulling.—If carburetter, mixture too weak owing to too small a jet, or constriction of fuel at some point. Excessive air-leak.

Heavy "thumpy" running.—If carburetter, mixture too rich; if accompanied by occasional misfiring probably float needle sticks, and gives rise to intermittent flooding.

Knock.—If carburetter, too poor a mixture.

Misfiring.—(Intermittent). If carburetter, too weak a mixture, caused probably by dirt or water in float chamber or jet.

(Rhythmic). If carburetter, too rich a mixture, caused by flooding, or the air-intake being choked up with dust.

Eight Stroking.—Always carburetter, too rich a mixture; intermittent flooding, owing to dirt on needle, or air-intake being choked with dust.

Flooding.—A certain amount of this over very bumpy roads is inevitable. Other causes are:—Dirt on needle valve seating, valve seating worn, distortion of gauze in union throwing needle to one side. punctured float. On the E type, prior to 1920, where the level can be altered, the spring collar is sometimes moved; in adjusting give about $\frac{1}{8}$ " up and down play to needle, and the level will be found correct. To remove dirt from needle valve seating, twist needle in fingers, pulling up at same time. Occasionally on new machines sawdust and dirt will be found in the petrol tank, and failing taking down tank and washing out, 100 miles or so must be covered before this washes out, and the flooding caused thereby stops.

Notice that the level of petrol is set above the jet, and that the jet is always submerged in petrol. The level is carefully set and tested at the works before carburetter is sent out, and ought not to be interfered with.

When the float chamber is flooding, petrol will be seen to trickle down round the bottom of the mixing chamber. This petrol comes through the two small holes in the base of the mixing chamber, which are provided to prevent accumulation of petrol at this spot. Petrol showing at this place may give the impression that the cone joint between the float chamber and the mixing chamber is leaking.

Machines ought not to be left standing for long periods without turning off petrol cock.

SECTION 11: FUELS.

Petrol.—At present, it is sold in four qualities:—Aviation spirit; Nos. 1, 2 and 3. Petrol Nos. 2 and 3 appear to be of very poor quality. The specific gravity of aviation spirit is 680, and some brands of present-day petrol go as far as 800.

These differences of petrol quality give a great deal of variation in the running of engines, and should always be taken into consideration.

Benzol.—When running on benzol, use a smaller jet. Spark lever must be further advanced. Benzol is specially good to run on when your engine knocks, owing to combustion chamber being carbonized, and you haven't got time to clean same. For heavy work, one-third petrol and two-thirds benzol makes a splendid pulling mixture. Benzol gives slightly more miles to the gallon.

Paraffin.—If from any cause you are compelled to run on paraffin, lower your compression as far as possible, set the spark later (about 4 m/m at full advance on a four-stroke, and 7 m/m on a two-stroke), and use as low a top gear ratio as possible.

Mixtures.—Half aviation spirit and half paraffin is quite good. Two-thirds No. 1 and one-third paraffin is a passable mixture for long runs, but is not to be recommended for traffic work with a sidecar. Half No. 3 and half paraffin can be run on, but starting is very difficult. Two-thirds benzol and one-third paraffin is fairly satisfactory, but difficult to start from cold. Shake all mixtures up well before starting, as they have a tendency to separate whilst at rest.

Alcohol Fuels.—When using "Discol" or other alcohol fuels, the following increase of main jet size should be made:

P.M.S.	2.	Approximately	22%
R.D.	2.	"	22%
R.D.	1.	"	32%

SECTION 12: "DODGES" TO GET YOU HOME.

Rubber tubing can be safely used temporarily to repair a fractured fuel pipe. Failing this, bind with insulating tape or soaped ordinary tape. Soap (household yellow preferred) is a fine stopper of petrol leaks.

If your throttle wire breaks on the two-lever model, change over the wires, fasten the air slide, if possible, so that it remains in the position for average running, or take it away altogether, and get home like that.

If you puncture your float badly or from any cause get bad flooding, adjust your petrol tap that it feeds just sufficient to keep your machine running at average speed.

Remember that the magneto is far more often the cause of erratic firing at very slow speed than the carburetter. An intelligent use of the magneto advance and retard lever will help in this direction. Other faults besides carburation causing bad, slow running are:—Weak exhaust valve springs, which would allow the exhaust valves to open during the suction stroke when the throttle is nearly closed; faulty plugs; sparking points in plug too far apart or too near; slight leakage from high tension cable to frame; weak magneto, dirty or untrue contact breaker points; cable sticking, etc.

SECTION 13.

Approximate sizes of nozzle to suit different sizes of engines are given below as an indication of what ought to be fitted.

For 1915 to 1919 models only:

8 h.p. twin,	nozzle 30
6 h.p. twin,	nozzle 28
3½ h.p. twin,	nozzle 27
2¾ h.p. twin,	nozzle 26
4½ h.p. single,	nozzle 32
3¾ h.p. single,	nozzle 31
2½ h.p. single,	nozzle 26

For sidecar work or very hilly country, a nozzle one, or perhaps two, numbers larger may be used.

SECTION 13A.

The size of nozzle best suited for the following two-stroke engines are:—

ENGINE	SIZE	TYPE OF CARB.	JET
Villiers	147	30 H.X.N.P.	29
	175	25 M.X.P.J.	30
	250	25 M.X.P.J.	32
	350	15 M.X.P.J.	35
Levis	247	30 N.Y.N.P.	28
Velocette	250	30 H.X.S.M.	27
	250 (2 port)	25 P.J.X.S.	30
Scott	Twin 2-stroke	15 N.Y.P.J.	37
AZA	175	30 H.Y.N.P.	27
Radco	Model 1	25 N.Y.P.J.	28
	Model 2	30 H.Y.S.M.	32
O.K.	250	30 H.X.N.P.	29
Enfield	250	30 H.X.N.P.	30

When corresponding, clients will oblige by giving fullest particulars and *date* of machine.

We are at all times very pleased to give every assistance and advice.

1926. LIST OF SETTINGS FOR VARIOUS 4-STROKE ENGINES

SECTION 13B. TYPES: 15MYPJ, 25MYPJ, 30HYPJ, 30HYPJ CARBURETTORS.

	15MYPJ		25MYPJ		30HYPJ		40YD		T11925				
	Jet	Thr. Valve	Cross Bore of Mix. Ch.	Jet	Thr. Valve	Cross Bore of Mix. Ch.	Jet	Thr. Valve	Cross Bore of Mix. Ch.	Thr. Valve			
Twin Cylinder 4-stroke	1000 C.C.	38	4	1"	34	4	1"	—	—	45	8	1"	8
	750 C.C.	—	—	—	32	4	1"	5	5	38	8	1"	8
	500 C.C.	—	—	—	30	4	1"	5	5	30	8	1"	8
	350 C.C.	—	—	—	—	—	—	5	5	34	8	1"	8
Single Cylinder 4-stroke	600 C.C.	40	4	1"	—	—	—	—	—	45	9	1"	11
	500 C.C.	38	4	1"	34	4	1"	—	—	43	9	1"	11
	350 C.C.	—	—	—	33	4	1"	5	5	43	8	1"	11
	150 C.C.	—	—	—	—	—	—	5	5	32	8	1"	8

This table is only intended to be used as a rough guide for those engines on which no carburettor test has been made.

ENGINE REVS. AT DIFFERENT SPEEDS—MILES PER HOUR.

SECTION 14.

Gear Ratio	Diam. of Driving Wheel, 26 in.									
	4	4½	4¾	5	5½	5¾	6	6½	7	7½
5	260	276	309	325	346	358	374	390	390	390
10	520	552	618	650	692	716	748	780	780	780
15	780	828	927	975	1038	1074	1122	1170	1170	1170
20	1040	1104	1236	1300	1384	1432	1496	1560	1560	1560
25	1300	1380	1545	1625	1730	1790	1870	1950	1950	1950
30	1560	1656	1854	1950	2076	2148	2244	2340	2340	2340
35	1820	1932	2163	2275	2422	2506	2618	2730	2730	2730
40	2080	2208	2472	2600	2768	2864	2992	3120	3120	3120
45	2430	2484	2781	2925	3114	3222	3366	3510	3510	3510
50	2600	2760	3090	3250	3460	3500	3740	3900	3900	3900
55	2860	3036	3399	3575	3806	3938	4114	4290	4290	4290
60	3120	3312	3708	3900	4152	4296	4488	4680	4680	4680
65	3380	3588	4017	4225	4498	4654	4862	5070	5070	5070
70	3640	3864	4326	4550	4844	5012	5236	5460	5460	5460
75	3900	4140	4635	4875	5190	5370	5610	5850	5850	5850
80	4160	4416	4944	5200	5536	5728	5984	6240	6240	6240

For 28 in. Wheels, multiply Revs. by 0.93. For 24 in. Wheels, multiply by 1.06.

SECTION 15. CUBIC CAPACITY OF STANDARD SIZE OF ENGINES AT PRESENT ON THE ROAD.

MILLIMETRES	C.C.	MILLIMETRES	C.C.
44 x 44	69	72 x 85.5	349
51 x 51	104	72 x 91	370
51 x 57	116	73 x 70	293
52 x 52	110	74 x 81	349
54 x 75	172	74 x 93	400
55 x 56	133	74.5 x 68	295
55 x 60	142	75 x 70	349
55 x 62	147	76 x 65.5	298
55 x 90	214	76 x 77	348
56 x 61	150	76 x 82	372
59 x 98	268	76 x 85	386
59 x 100	273	77 x 105	480
60 x 60	170	79 x 100	400
60 x 61	172	80 x 98	403
60 x 70	198	82 x 94	406
60 x 74	209	82 x 112	502
60 x 75	214	82 x 120	633
60 x 76	215	82.5 x 93	497
60 x 88	249	84 x 89	493
60 x 90	254	84 x 90	499
62 x 70	211	84 x 100	555
62 x 90	272	84.5 x 88.0	499
63 x 80	240	85 x 85	370
63 x 88	274	85 x 85	482
64 x 70	225	85 x 88	499
64 x 77	248	85 x 97	550
65 x 75	249	86 x 96	558
67 x 70	247	86.4 x 85	499
68 x 76	276	87 x 100	594
69 x 80	290	87 x 110	654
69 x 91	348	87.3 x 101	604
70 x 64.5	248	88 x 85	516
70 x 70	260	88 x 95	578
70 x 76	293	89 x 89	554
70 x 90	346	89 x 99	597
71 x 88	348	89 x 120	749
72 x 72	293	90 x 77.5	493
72 x 76	300	90 x 85	541

In the case of multi-cylinder engines, multiply by the No. of cylinders.

SECTION 16

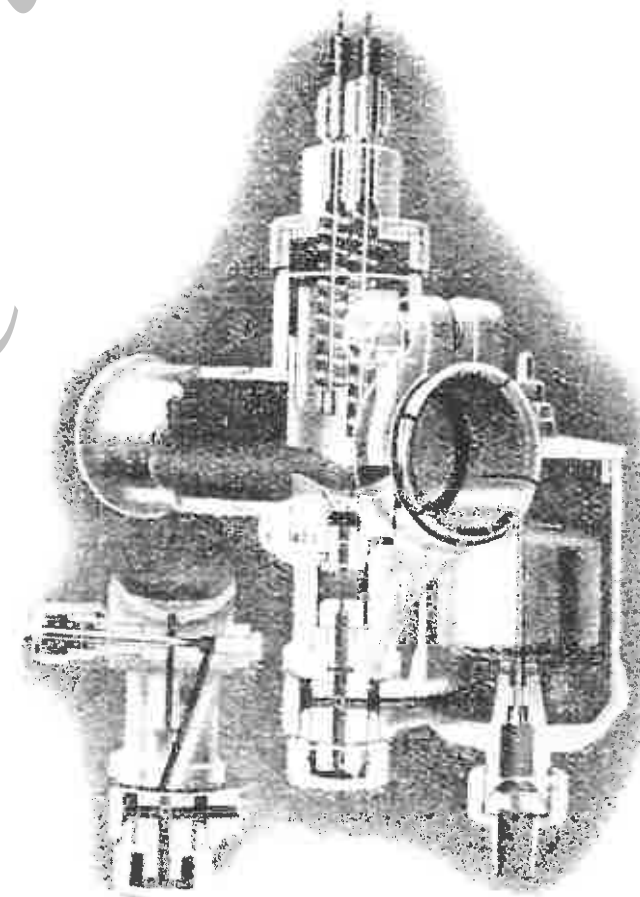

PILOT JET CARBURETTER

SECTION 17

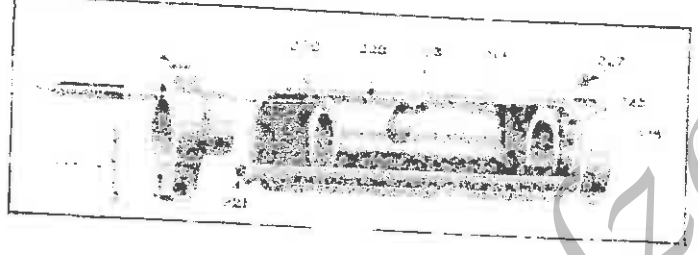
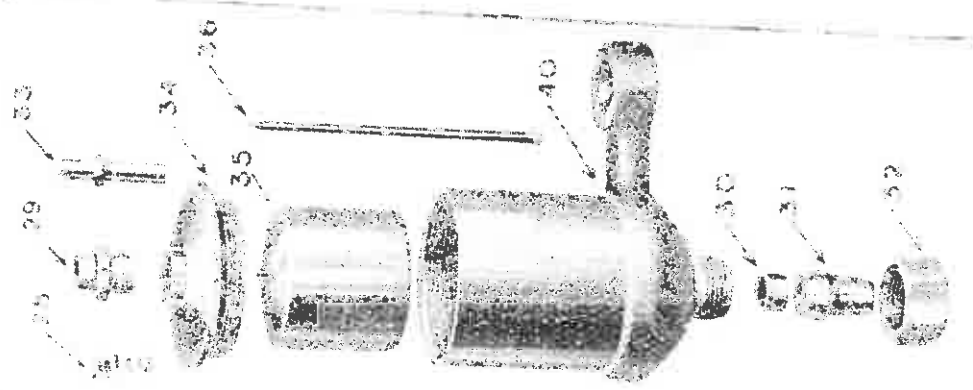

TWIST GRIP PARTS (D. TYPE)

ТИПЫ: 30НУДА, 30НУДА, 30НУСП, 30НУСП
MIXING CHAMBER PARTS

ТИПЫ: 30НУДА, 30НУСП, 30НУСП

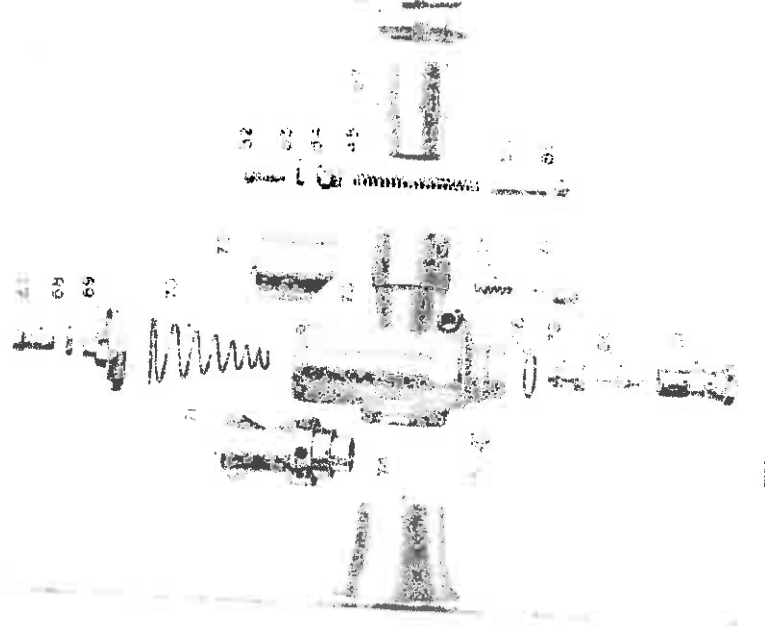

ТИПЫ: 10НУСП, 10НУСП

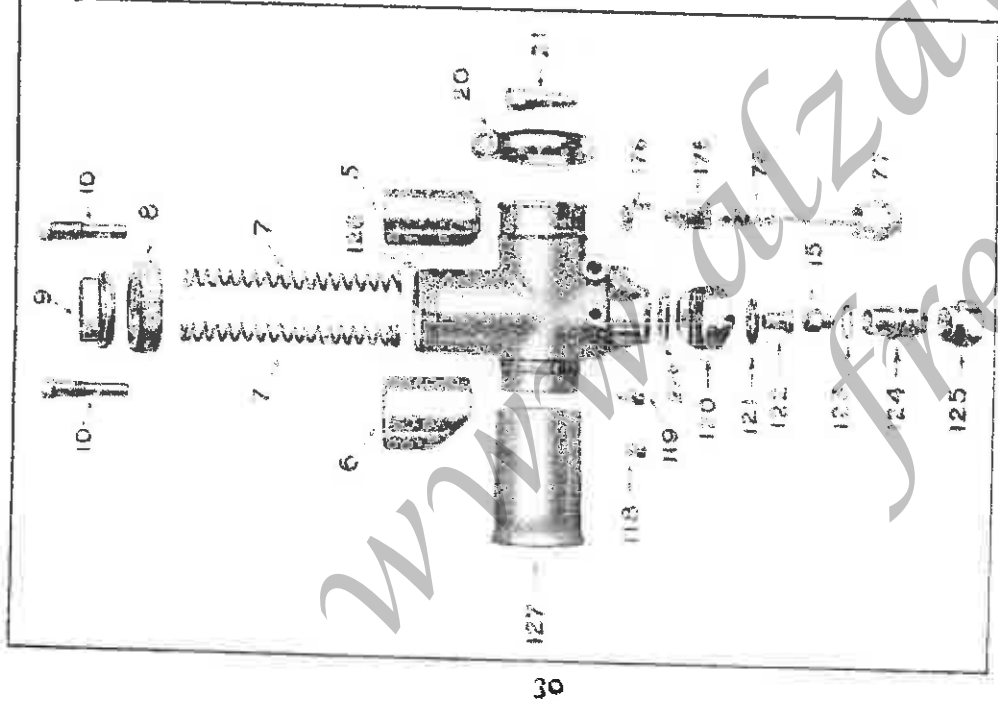

TYPES: 15MYPJ, 25MYPJ, 30MYPJ, 15HXPJ, 25HXPJ, 30HXPJ

15MYDM, 25MYDM, 15MIYSP, 35MIYSP, 15HXDM, 25HXDM, 15HXSP, 25HXSP

MIXING CHAMBER PARTS

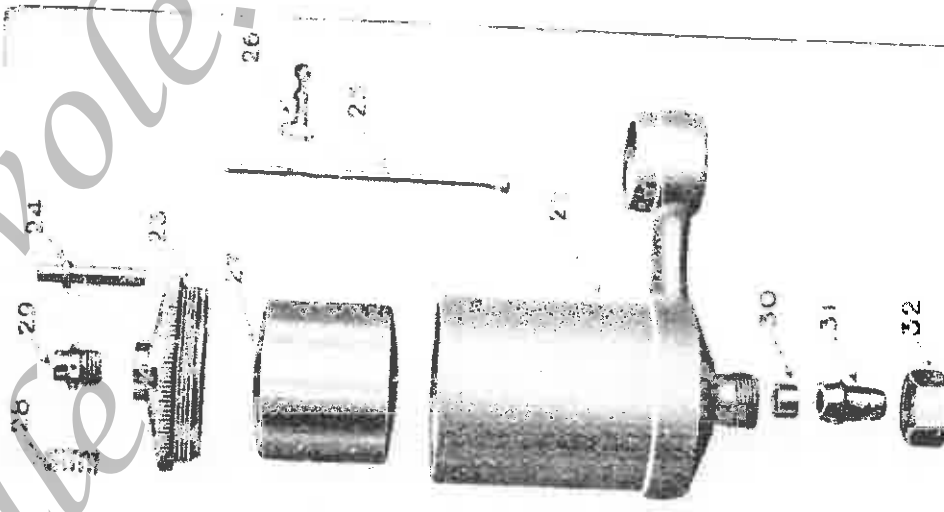
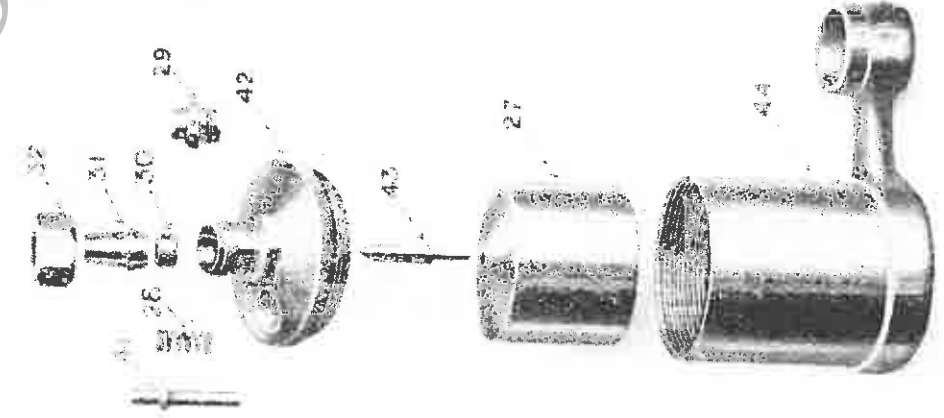

MIXING CHAMBER PARTS

NAME OF PART	TYPES: 15MYDM, 25MYDM 15MYSP, 25MYSP, 15HXDM 25HXDM, 15HXSP, 25HXSP		TYPES: 15TTS, 25TTS		TYPES: 10TTS		TYPES: 30HYDM, 30HXDM 30YSP, 30XSP		TYPE: 30Y		TYPE: 40Y	
	No.	Price s. d.	No.	Price s. d.	No.	Price s. d.	No.	Price s. d.	No.	Price s. d.	No.	Price s. d.
Mixing ch. & adapter	1	8 6	126	10 0	71	12 9	71	17 0	52	8 6	51	8 0
Mixing chamber	2	1 9			73	73						142
Air intake	3	10										
Air intake gauze	4	1 9										
Air intake cover	5	3 0	5	3 0	85	1 0	85	1 0	53	1 9		
Air valve	6	3 10	6	3 10	72	3 10	72	4 3	49	3 0	49	3 0
Throttle valve	7	3 3	7	3 3					50	3 10	50	3 10
Valve spring	8	1 9	8	1 9					48	3 48	48	3 139
Mixing chamber cap	9	1 9	9	1 9	69	1 9	69	2 2	47	1 9	47	1 9
Mixing chamber top	10	4 10	10	4 10					46	1 9	46	1 9
Cable adjuster	11	3 0	120	3 0					45	4 45	45	4 137
Sprayer (top half)	12	2 11	121						54	3 0	54	3 0
Sprayer washer	13	2 1							55		55	
Sprayer (bottom half)	14	1 6							57	1 6	57	1 6
Mixing ch. union nut	15	5 15	15	5 80					15	5 15	15	5 148
Jet	16	2 123	123	2					58	2	58	2
Jet holder top washer												

Jet holder	17	1 9	124	1 9	81	1 9	81	1 9	81	1 9	56	1 9	39	1 0
Jet holder bottom washer	18	2												
Jet holder nut	19	3 125									59			
Outlet clip	20	1 9	20	1 9	20	1 9	20	2 20	1 0	20	1 9	144	9	
Outlet clip-pin	21	3	21	3 21	21	3 21	21	3 21	3 21	3 21				
Pilot needle spring			76	2 76	76	2 76	76	2						
Pilot needle			77	1 0	77	1 0	77	1 0						
Pilot needle insert			175	1 0	175	1 0	175	1 0						
Pilot needle spring catch														
Washer (Fl. Ch. Lug)			176	2 176	176	2 176	176	2						
Plug screw			220	2										
Sprayer locating screw			118	2										
Sprayer screw			119	2										
Air tube	127	2 6	127	2 6	74	2 6	74	3 0	127	2 6				
Air valve spring					48	3 48	48	3						
Throttle valve spring					70	3 70	70	3						
Throttle cable adjuster					67	4 67	67	4						
Throttle cable														
Adjuster nut					68	2 68	68	2						
Adapter (see 73)					71	71	71							
Locking screw					75	2 75	75	2						
Fibre washer					78	2 78	78	2						
Primary choke					79	1 9	79	1 9						
Air cable adjuster					82	1 82	82	4						
Air cable adjuster nut					83	2 83	83	2						
Air barrel top					84	7 84	84	7						
Air valve nipple					86	2 86	86	2						
Outlet liner					87	9 87	87	9						
Jet plug														149

PARTS PECULIAR TO "EW" DOUGLAS CARBURETTER
TYPE 30 HYPJ OR TYPE 30 HYW

Split ring for induction joint ..	s. d.	Packing ring for induction joint ..	s. d.
Nut for induction joint ..	0	Hot air pipe and ring ..	6
	2 0		5 0

CONTROL PARTS

NAME OF PART	MID & MOD Control (Double Lever)		MIS, MOS Control (Single Lever)		T30 Control (Double Lever)	
	No.	Price s. d.	No.	Price s. d.	No.	Price s. d.
Bottom control spring ..	91	2	91	2	—	—
Control clip half ..	92	6	92	6	—	6
Control clip rivets ..	93	2	93	2	93	2
Control clip screw ..	95	3	95	3	95	3
Control bolt ..	108	3	88	3	96	3
Control cap ..	109	5	89	5	97	5
Locking washer ..	110	—	—	—	—	—
Regulating flange ..	111	—	—	—	—	—
Top control spring washer ..	112	2	—	—	—	—
Air lever ..	113	3	—	—	—	—
Division plate ..	114	5	—	—	98	2
Throttle lever ..	115	5	—	—	100	3
Control body only ..	116	3	—	—	102	5
Control clip nut ..	117	1 10	94	1 10	103	3
Control lever ..	—	3	117	3	105	1 10
Control bush ..	—	—	90	3 5	117	3
Air slide ..	—	—	—	—	—	—
					99	2
					101	see 104

Throttle slide and air slide (per pair) ..	—	—	—	—	—	104	5
Control disc ..	—	—	—	—	—	106	2
Slotted cap ..	—	—	—	—	—	107	5
Cables (inner and outer) per length ..	—	3 0	—	3 0	—	—	3 0
Cables (inner and outer) per pair ..	—	5 0	—	—	—	—	5 0
Cable nipples ..	—	2	—	2	—	—	2
Packing pieces (per pair) ..	—	6	—	6	—	—	6
TWIST GRIP PARTS 1025							
Slide body ..	155	3 0	—	—	—	—	2 0
Slide ..	156	6	—	—	—	—	1 6
Body clip screw ..	157	3	—	—	—	—	3 0
Oil eyelet ..	177	6	—	—	—	—	2 0
Locating screw ..	158	3	—	—	—	—	1 0
Friction nut ..	159	1 9	—	—	—	—	3
Rubber grip and liner complete ..	160	3 6	—	—	—	—	4
Dummy Grip ..	161	2 0	—	—	—	—	3
PULL-UP LEVER PARTS							
Pull-up lever bracket ..	167	2 8	—	—	—	—	1 6
Pull-up lever ..	168	3 5	—	—	—	—	—
Cable end for pull-up lever ..	169	10	—	—	—	—	—
Fulcrum pin for pull-up lever ..	170	3	—	—	—	—	—
Clip screw for pull-up lever ..	171	3	—	—	—	—	—
Fulcrum pin nut ..	172	3	—	—	—	—	—
Clip top half for pull-up lever ..	173	6	—	—	—	—	—
"D" TYPE TWIST GRIP PARTS							
End clips (front) ..	217	2 0	—	—	—	—	2 0
" " (rear) ..	218	1 6	—	—	—	—	1 6
Sliding sleeve ..	219	3 0	—	—	—	—	3 0
Rotating sleeve ..	220	2 0	—	—	—	—	2 0
Guide strip ..	221	1 0	—	—	—	—	1 0
End clip screw ..	222	3	—	—	—	—	3
Roller ..	223	4	—	—	—	—	4
Friction spring ..	225	3	—	—	—	—	3
Rubber grip ..	226	1 0	—	—	—	—	1 0
Grab screw ..	227	2	—	—	—	—	2
Liner 1" x 3/4" (not shown) ..	228	1 6	—	—	—	—	1 6
When ordering spare parts clients will assist considerably by giving, whenever possible, type of carburetter and date, make and h.p. of engine.							
T 30 Strangler complete ..	3/-						
T 40 ..	2/-						

FLOAT CHAMBER PARTS

NAME OF PART	TYPES: 1SMVWP, 2SMVWP,		TYPES: 1SMYDM, 2SMYDM,		TYPES: 1SMVSP, 1OMVSP,		TYPES: 1SHXSP, 2SHXSP,		TYPES: 1SHXDM, 2SHXDM,		TYPES: 1SHXSP, 3OHXSP,		TYPES: 3OHXDM,		TYPES: 3OHVDM,		TYPES: 3OHVSP,		TYPES: 3OHVDM,		TYPES: 3OHVSP,		TYPES: 4OYD		
	No.	Price s. d.	No.	Price s. d.	No.	Price s. d.	No.	Price s. d.	No.	Price s. d.	No.	Price s. d.	No.	Price s. d.	No.	Price s. d.	No.	Price s. d.	No.	Price s. d.	No.	Price s. d.	No.	Price s. d.	
Float chamber only	22	12 0	44	12 0	40	8 6	40	8 6	40	8 6	37	8 6	37	8 6	37	8 6	37	8 6	37	8 6	37	8 6	133	5 0	
Float chamber cover with tickler parts	23	4 3	42	4 3	34	4 3	34	4 3	34	4 3	34	4 3	34	4 3	34	4 3	34	4 3	34	4 3	34	4 3	133	5 0	
Float chamber cover only	23	2 11	42	2 11	34	2 11	34	2 11	34	2 11	34	2 11	34	2 11	34	2 11	34	2 11	34	2 11	34	2 11	132	2 0	
Tickler	24	7 41	41	7 41	33	7 41	33	7 41	33	7 41	33	7 41	33	7 41	33	7 41	33	7 41	33	7 41	33	7 41	132	2 0	
Tickler spring	28	2 28	28	2 28	28	2 28	28	2 28	28	2 28	28	2 28	28	2 28	28	2 28	28	2 28	28	2 28	28	2 28	132	2 0	
Tickler body	20	7 29	29	7 29	29	7 29	29	7 29	29	7 29	29	7 29	29	7 29	29	7 29	29	7 29	29	7 29	29	7 29	132	2 0	
Needle valve	25	10 43	43	10 43	36	9 65	36	9 65	36	9 65	36	9 65	36	9 65	36	9 65	36	9 65	36	9 65	36	9 65	132	2 0	
Needle clip	26	3	3	3	35	2 6	35	2 6	35	2 6	35	2 6	35	2 6	35	2 6	35	2 6	35	2 6	35	2 6	132	2 0	
Float	27	2 6	27	2 6	35	2 6	35	2 6	35	2 6	35	2 6	35	2 6	35	2 6	35	2 6	35	2 6	35	2 6	132	2 0	
Petrol gauze	30	5 30	30	5 30	30	5 30	30	5 30	30	5 30	30	5 30	30	5 30	30	5 30	30	5 30	30	5 30	30	5 30	132	2 0	
Petrol union nipple	31	3 31	31	3 31	31	3 31	31	3 31	31	3 31	31	3 31	31	3 31	31	3 31	31	3 31	31	3 31	31	3 31	134	3 6	
Petrol union nut	32	0 32	32	0 32	32	0 32	32	0 32	32	0 32	32	0 32	32	0 32	32	0 32	32	0 32	32	0 32	32	0 32	135	6 6	
Float chamber screws																								38	3

SECTION 18

1920

SUCCESSSES OF AMAC CARBURETTERS

TOURIST TROPHY, I.O.M.
 Junior FIRST
 Lightweight FIRST

FRENCH GRAND PRIX
 500 c.c. FIRST
 350 c.c. FIRST
 175 c.c. FIRST

GRAND PRIX D'EUROPE
 (BELGIUM)
 350 c.c. FIRST
 175 c.c. FIRST

GERMAN GRAND PRIX
 RACES (KOLBERG, JULY 3rd)
 350 c.c. FIRST
 250 c.c. FIRST
 175 c.c. FIRST

(EIFEL, JUNE 16th)
 750 c.c. FIRST
 500 c.c. FIRST
 350 c.c. FIRST
 600 c.c. Sidecar FIRST
 Over 600 c.c. Sidecar FIRST

(AVUS, JUNE 13th)
 1,000 c.c. FIRST
 250 c.c. FIRST
 175 c.c. FIRST
 600 c.c. Sidecar FIRST

AUSTRIAN T.T.
 Junior FIRST
 Lightweight FIRST

HUNGARIAN T.T.
 Unlimited FIRST
 Senior FIRST
 Junior FIRST

DUTCH T.T.
 750 c.c. FIRST
 350 c.c. FIRST
 250 c.c. FIRST

SOUTH AFRICAN T.T.
 (KRAGGA-KAMA COURSE)
 650 c.c. FIRST
 350 c.c. FIRST
 175 c.c. FIRST
 Unlimited FIRST

LEINSTER HUNDRED
 600 c.c. FIRST
 350 c.c. FIRST
 250 c.c. FIRST

ULSTER GRAND PRIX
 350 c.c. FIRST
 500 c.c. FIRST
 Over 500 c.c. FIRST

GRAND PRIX OF NATIONS
 (MONZA TRACK, ITALY)
 125 c.c. FIRST
 350 c.c. FIRST
 500 c.c. FIRST

GRAND PRIX DE FRANCE
 (MOUTHLERY, FRANCE)
 175 c.c. FIRST
 250 c.c. FIRST

WINNERS OF 24 BRITISH T.T. RACES
 ALSO MORE BRITISH AND WORLD'S RECORDS THAN
 ALL OTHER MAKES OF MOTOR CYCLE CARBURETTER

AMAC LTD.
HOLFORD WORKS, PERRY BARR, BIRMINGHAM

SECTION 19

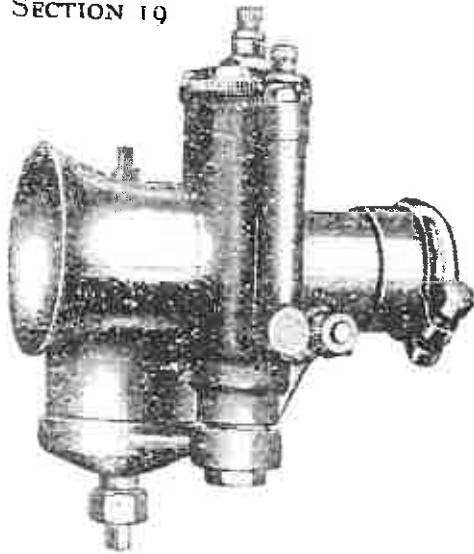

T.T. MODEL FOR RACING
(MADE IN 3 SIZES: 10, 15, 25)

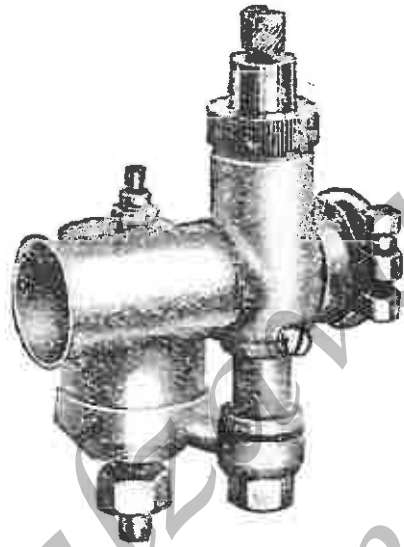

30 HYNP



TYPE M. DOUBLE CONTROL

38

AMAC LTD.
HOLFORD WORKS, PERRY BARR, BIRMINGHAM

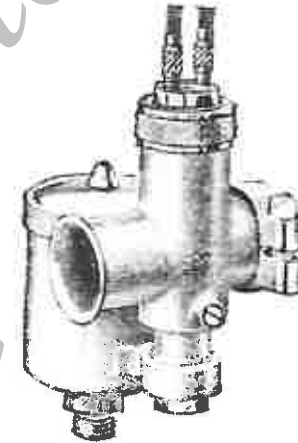

40 YD
(FOR ULTRA LIGHT-WEIGHT MACHINES)

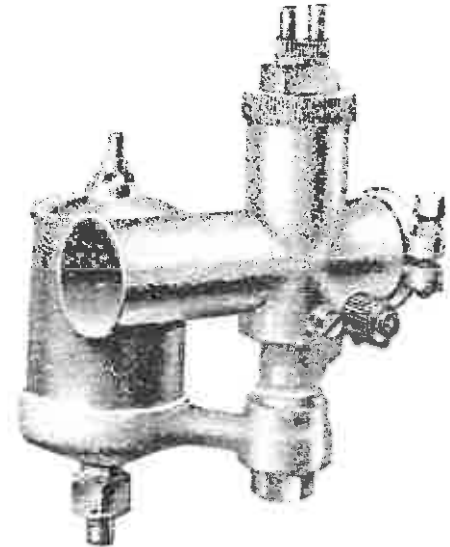

PILOT JET MODEL
(MADE IN 3 SIZES: 15, 25, 30)

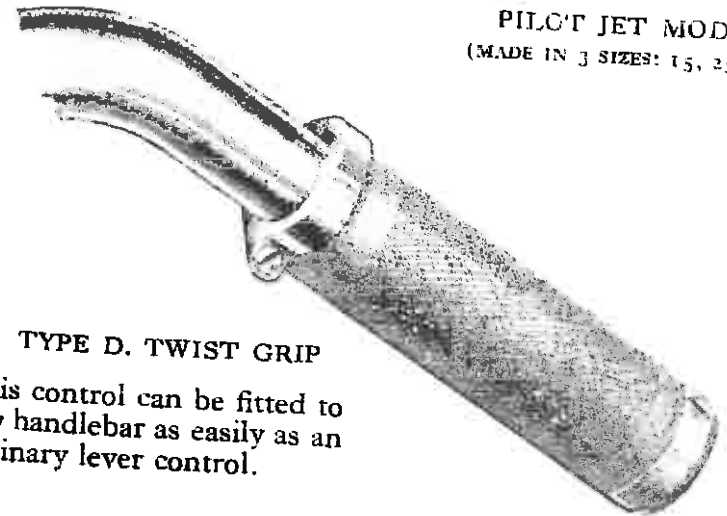

TYPE D. TWIST GRIP
This control can be fitted to
any handlebar as easily as an
ordinary lever control.

39

SECTION 20

PRICES OF AMAC CARBURETTORS

Type No.	Type of Carburettor	Cubic Capacity of Engine		Outside Diam. of Inlet Pipe	Internal Bore of Carb.	Outside Diam. of Handlebar	Standard Length of Cable	Weight with Control	Price complete	Price less Control and Cable
		Single	Twin							
40	YD	150 c.c. and under	350 c.c. and under	1" or 1 1/8"	3/8"	1" or 1 1/8"	3' 0"	1 lb. 3 1/2	43/-	33/-
30	HYNP	350 c.c. and under	600 c.c. and under	1" or 1 1/8"	3/8"	"	3' 0"	2 1	51/-	41/-
30	PILOT JET	350 c.c. and under	600 c.c. and under	1" or 1 1/8"	3/8"	"	3' 0"	2 0 1/2	51/-	41/-
25	PILOT JET	350 c.c. to 500 c.c.	600 c.c. to 1000 c.c.	1" or 1 1/8"	3/8" or 1"	"	3' 2"	2 13	57/-	45/-
15	PILOT JET	500 c.c. and over	1000 c.c. and over	1 1/8"	1"	"	3' 10"	3 1 1/2	61/-	49/-
25	T.T.1925	350 c.c. and under	750 c.c. and under	1" or 1 1/8"	3/8" or 1"	"	3' 2"	3 3 1/2	62/-	50/-
15	T.T.1925	350 c.c. to 600 c.c.	750 c.c. to 1000 c.c.	1 1/8" or 1 1/4"	3/8" or 1"	"	3' 4"	3 7	66/-	54/-
10	T.T.1925	500 c.c. and over	1000 c.c. and over	1 1/4" or 1 1/2"	1 1/8"	"	3' 4"	3 15	71/-	59/-

Flanged outlets and top feed float chambers can be supplied when required.

When ordering it is necessary that full particulars as to the name, date and horse-power of the machine and the size of the induction pipe and handlebar should be given.

The T.T. 1925 is the racing pattern carburettor.

All Amac carburettors are now fitted with adjustable pilot jets except the ultra-lightweight model type 40 YLJ and the type 30 HYNP.

PRICES OF AMAC CONTROLS

M Double Lever Control, less Cables	.. 12/-	M Double Lever Control, with Cables	17/9
M Single	.. 10/3	M Single	13/7
Std. and Short Twist Grip Control, less Cable, 9/-		Std. and Short Twist Grip Control, with Cables, 11/-	
Long Twist Grip Control, less Cable	.. 10/-	Long Twist Grip Control, with Cables	12/-